



POLARGY

DATE CREATED
August 14, 2017

DATE MODIFIED
August 16, 2017

LOCATION
Sunnyvale, CA, USA

PROJECT NAME
**Flat-Pack
Aisle Containment
Installation Guide**

01

Step #1 Install all thread supports according to layout provided in shop drawing.

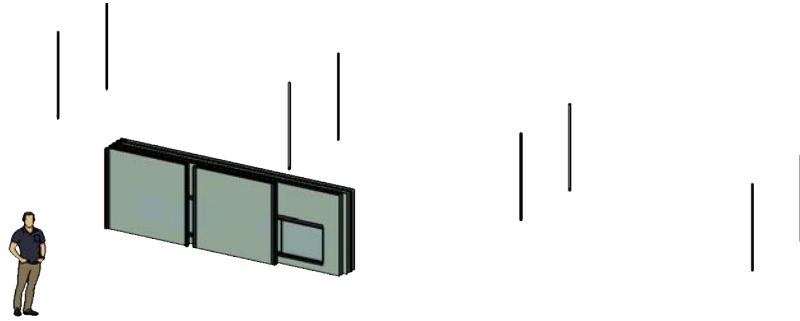

ALL THREAD SUPPORT RODS
ALIGN TO CONNECTORS ●

Step #2 Layout and assemble the system on the floor.

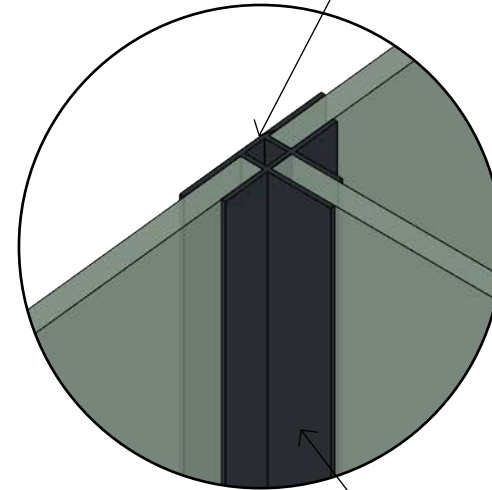
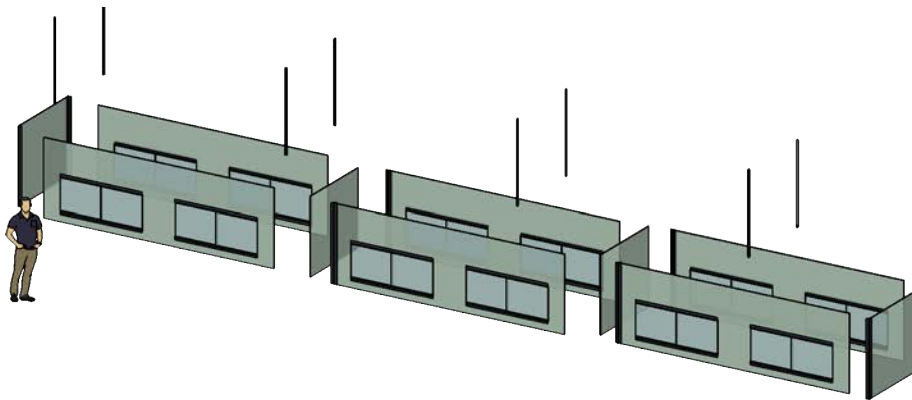

4 SELF TAPPING SCREWS
PER SIDE OF EACH CONNECTOR ●



POLARGY

DATE CREATED
August 14, 2017

DATE MODIFIED
August 16, 2017

LOCATION
Sunnyvale, CA, USA

PROJECT NAME
**Flat-Pack
Aisle Containment
Installation Guide**

Step #3 Prepare crew and or Genie Lifts to raise assembled system over all thread and up into the ceiling. For reference, a 30' long x 4' wide x 4' tall system weighs 200 lbs.

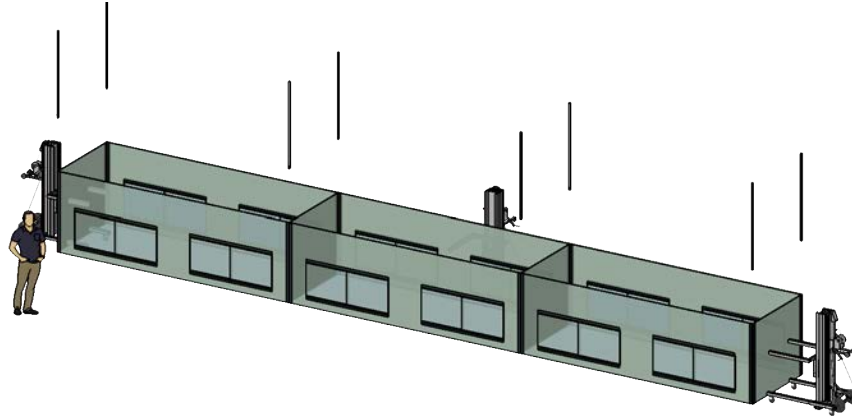

• SUPPORT RODS PASS THROUGH CONNECTORS

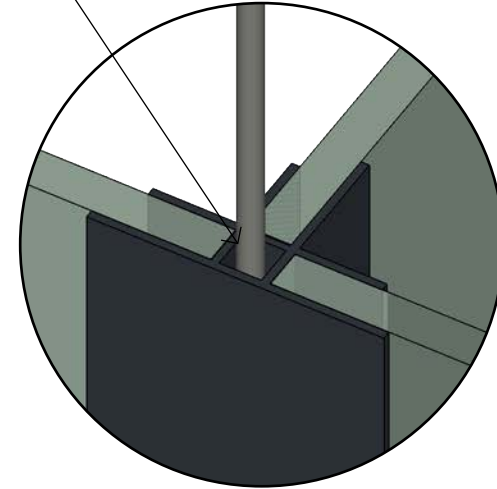

Step #4 Lift system into place, secure with bottom bolts.

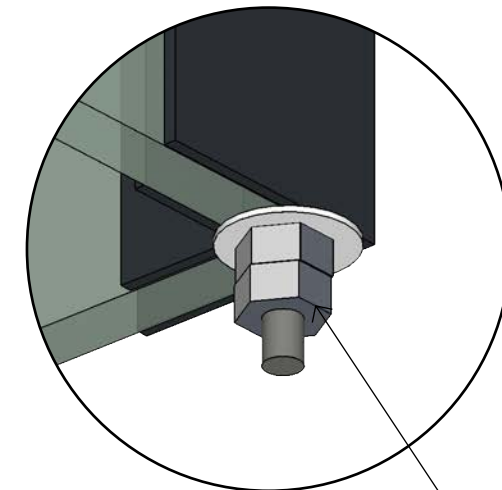
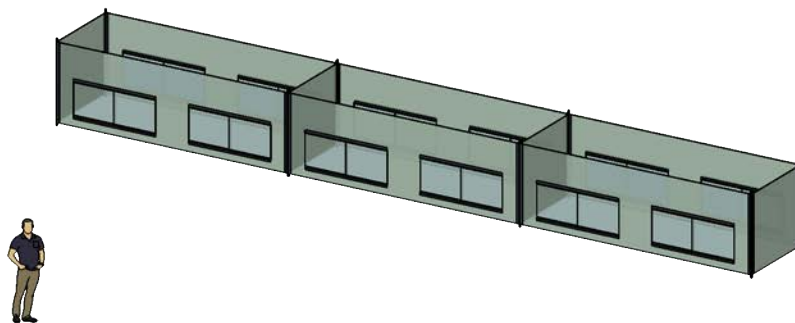

BOTTOM BOLT/WASHER SECURES SYSTEM AT EACH CONNECTOR •

Step #5 Install remainder of system, doors and infill panels, according to shop drawings.